

Mündung 1 M 2:1  
 Gänge: 1  
 Steigung: 3mm  
 Windungen: 1,875

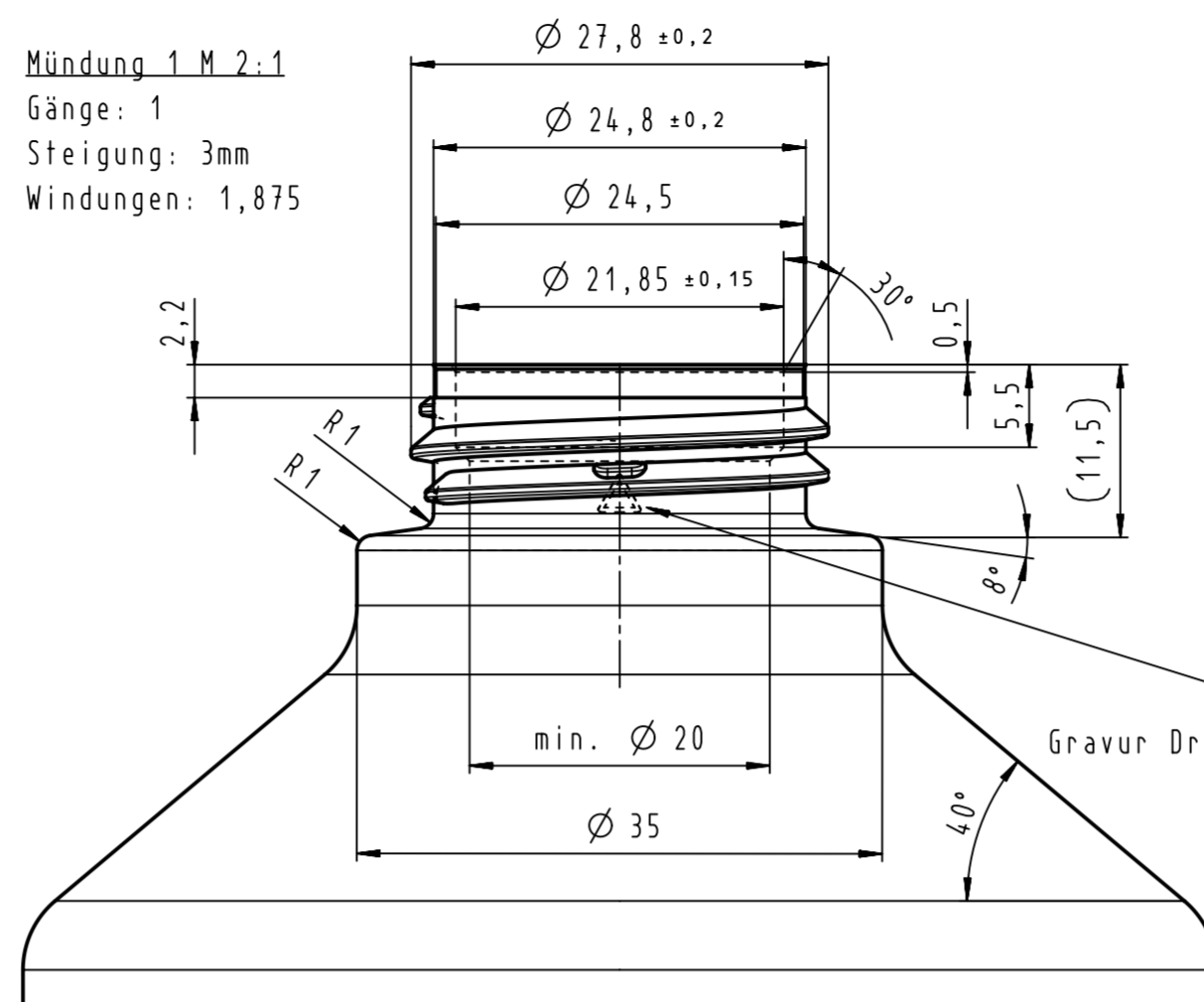

Mündung 1 M 2:1  
 Gänge: 1  
 Steigung: 4,23mm  
 Windungen: 2

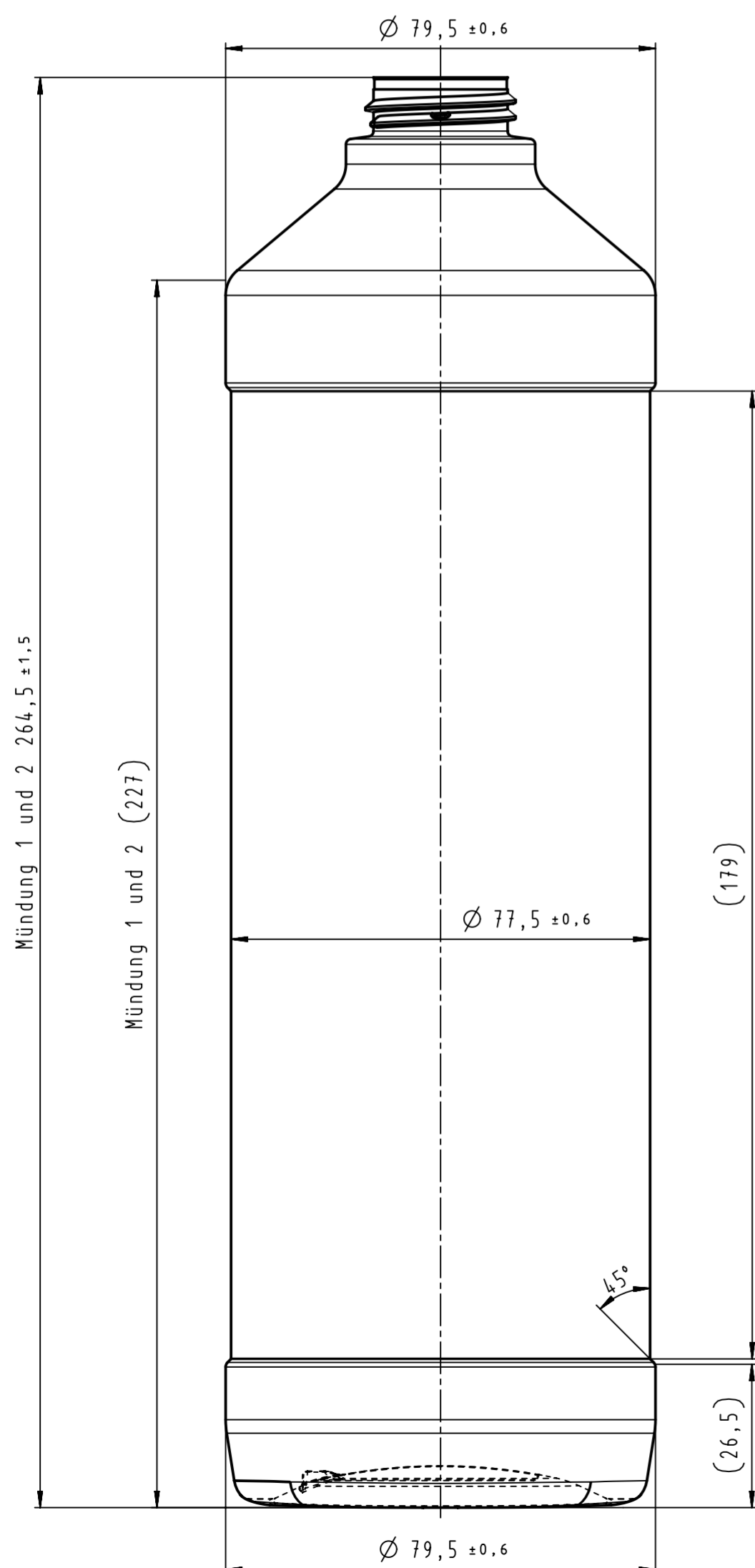
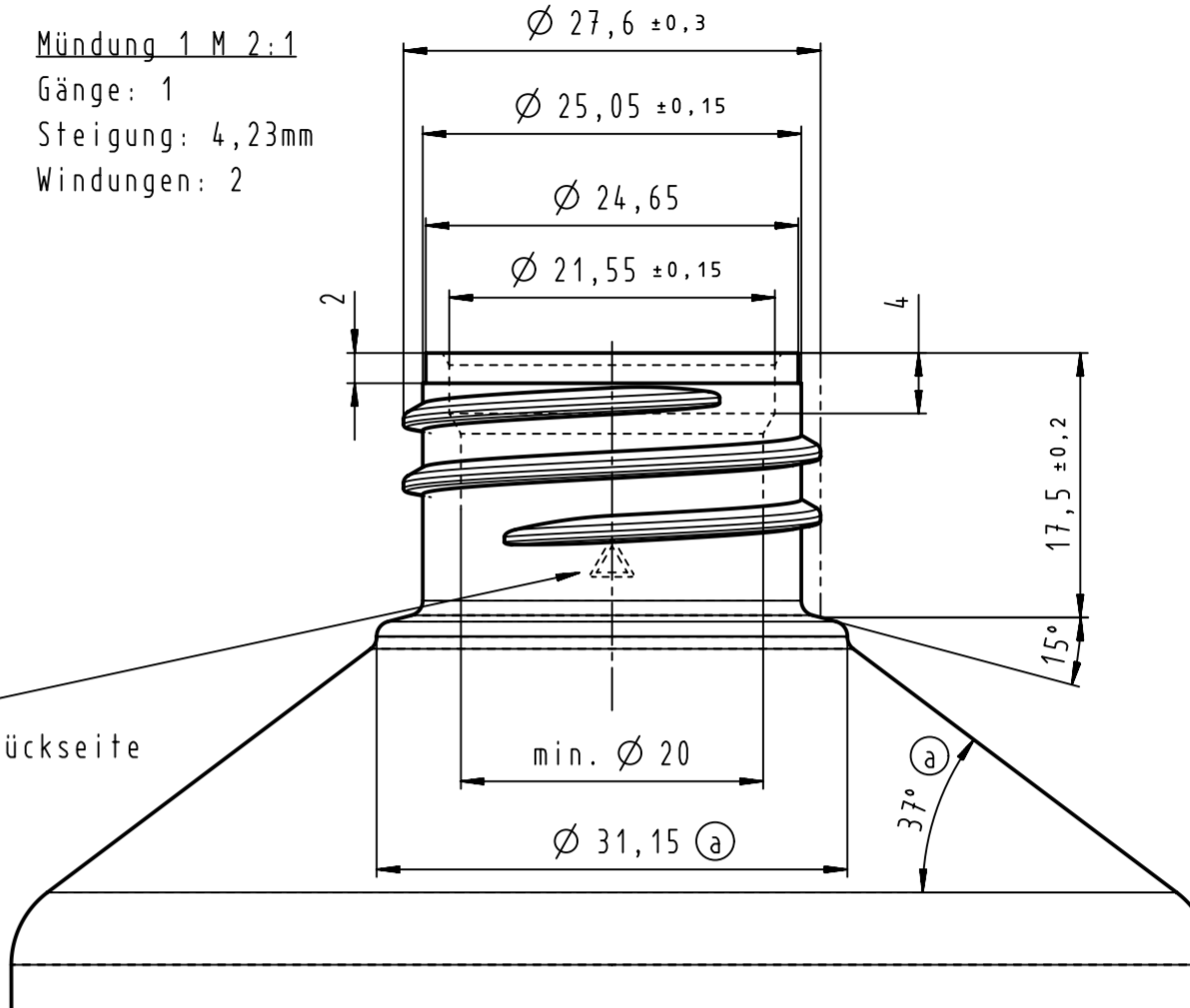

Detail Mündung 1 M 5:1

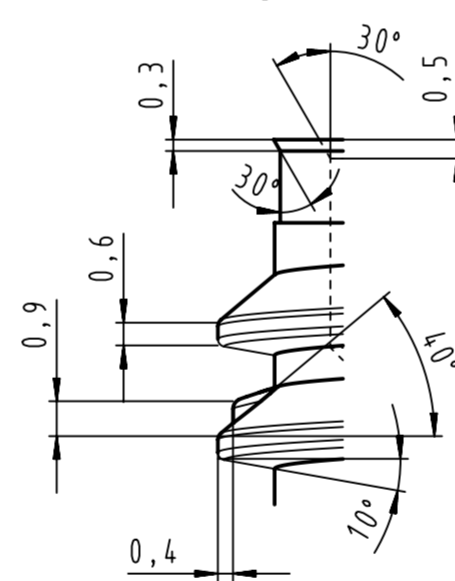

Gewindedetail Mündung 2 M 5:1

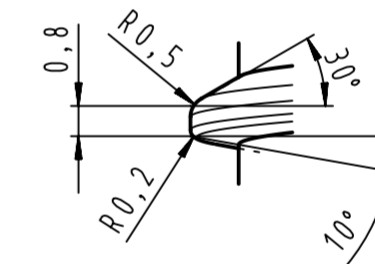

Material: PE-HD  
 (a) Gewicht : 39g ± 2g  
 Volumen Mündung 1: 1080ml ± 15ml  
 Volumen Mündung 2: 1074ml ± 15ml

Projekt-Nr.: 54-220-0228		Allgemeine Toleranzen DIN ISO 2768-mk Blasartikel DIN ISO 2768-c Spritzgussartikel DIN 16742-T66		Maßstab: 1:1 (2:1)	54-216-493 E1
2020		Datum	Name	Glasreiniger 1000ml	
Bearb.		08.05.20	Nobis		
Gepr.		08.05.20	Nobis		
Ersetzt für:		Ersetzt durch:			
a war 44g / #33 / 37,6*		11.05.20	No.	A2-54-31110a	
Zust.		Änderung	Datum		
Wefo		BLASFORMEN		Blatt 1/1	