

MOULD NUMBER/
CAVITY NUMBER

SUPPLIER LOGO

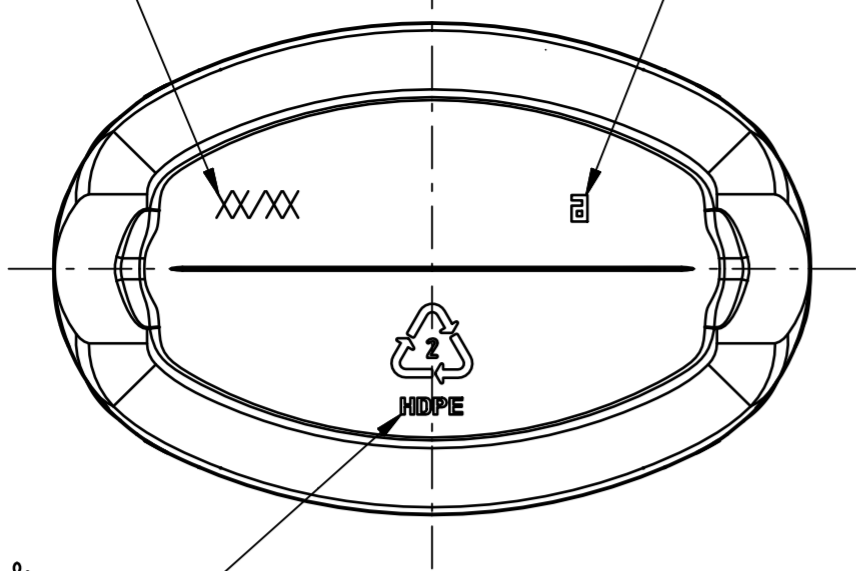

MATERIAL &
RECYCLING SYMBOL

NECK DETAIL:

SCALE 2:1

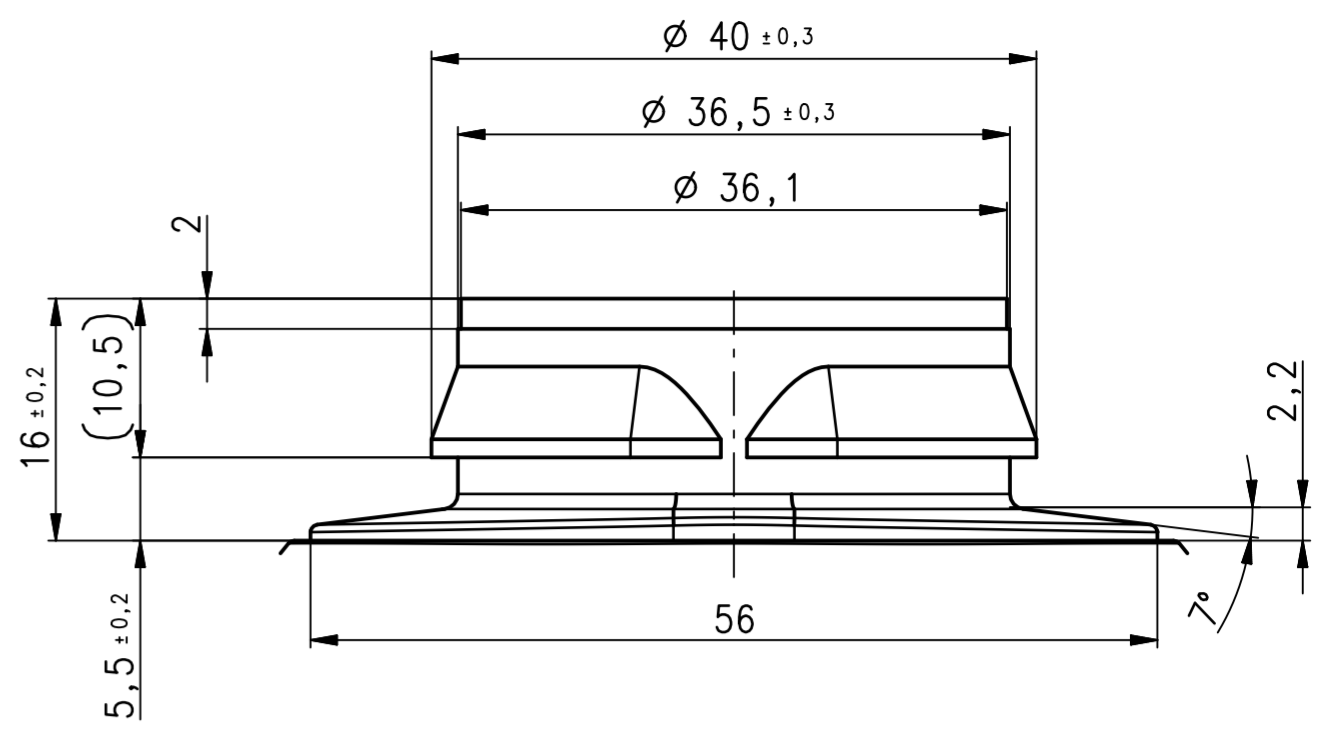

NECK DETAIL:

SCALE 5:1

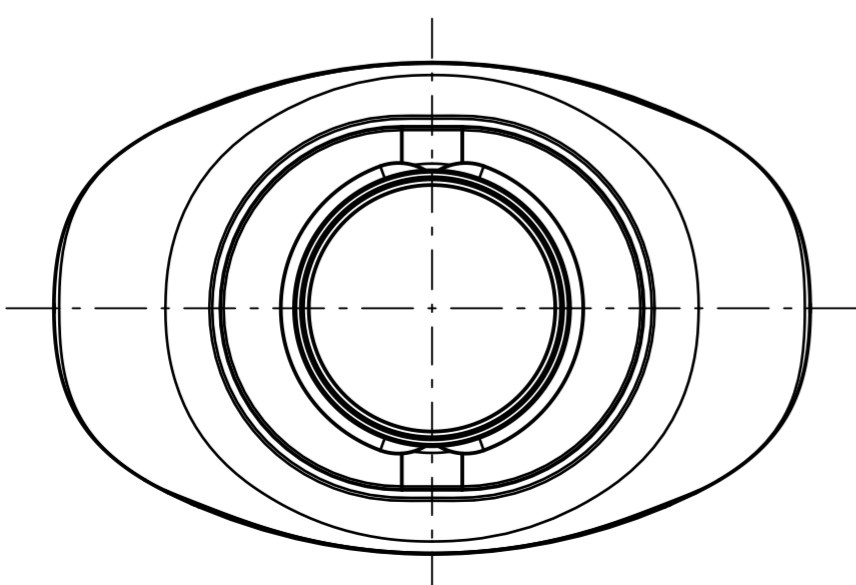
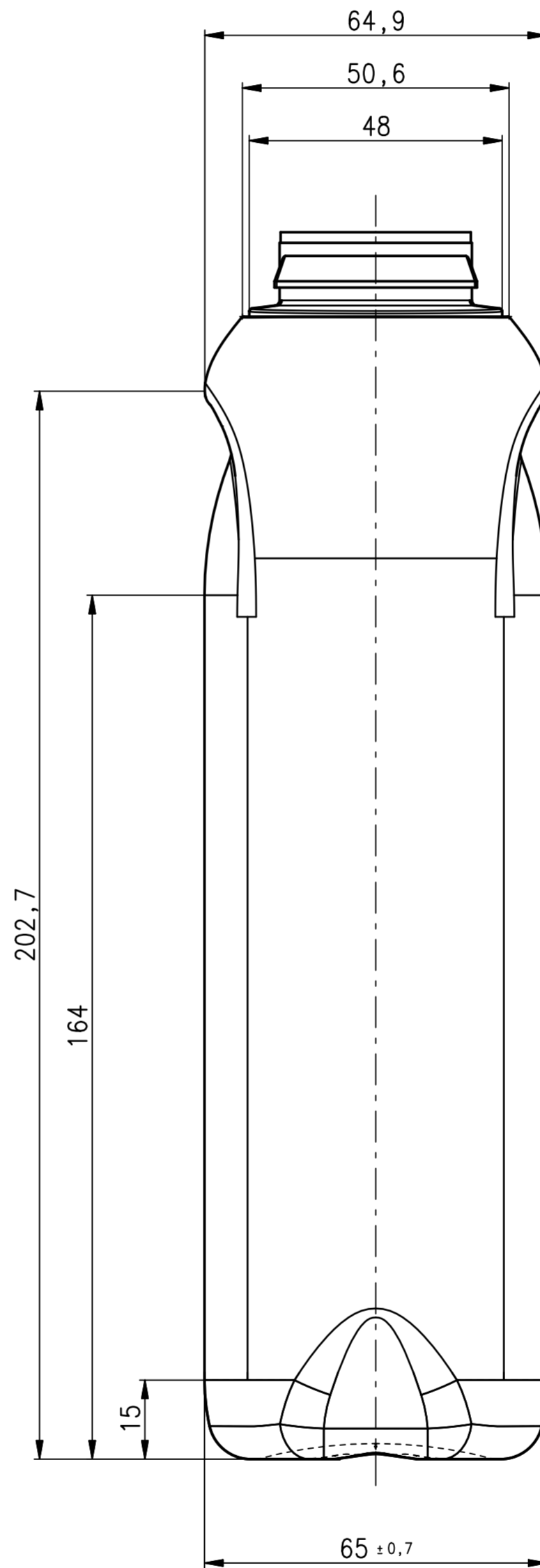
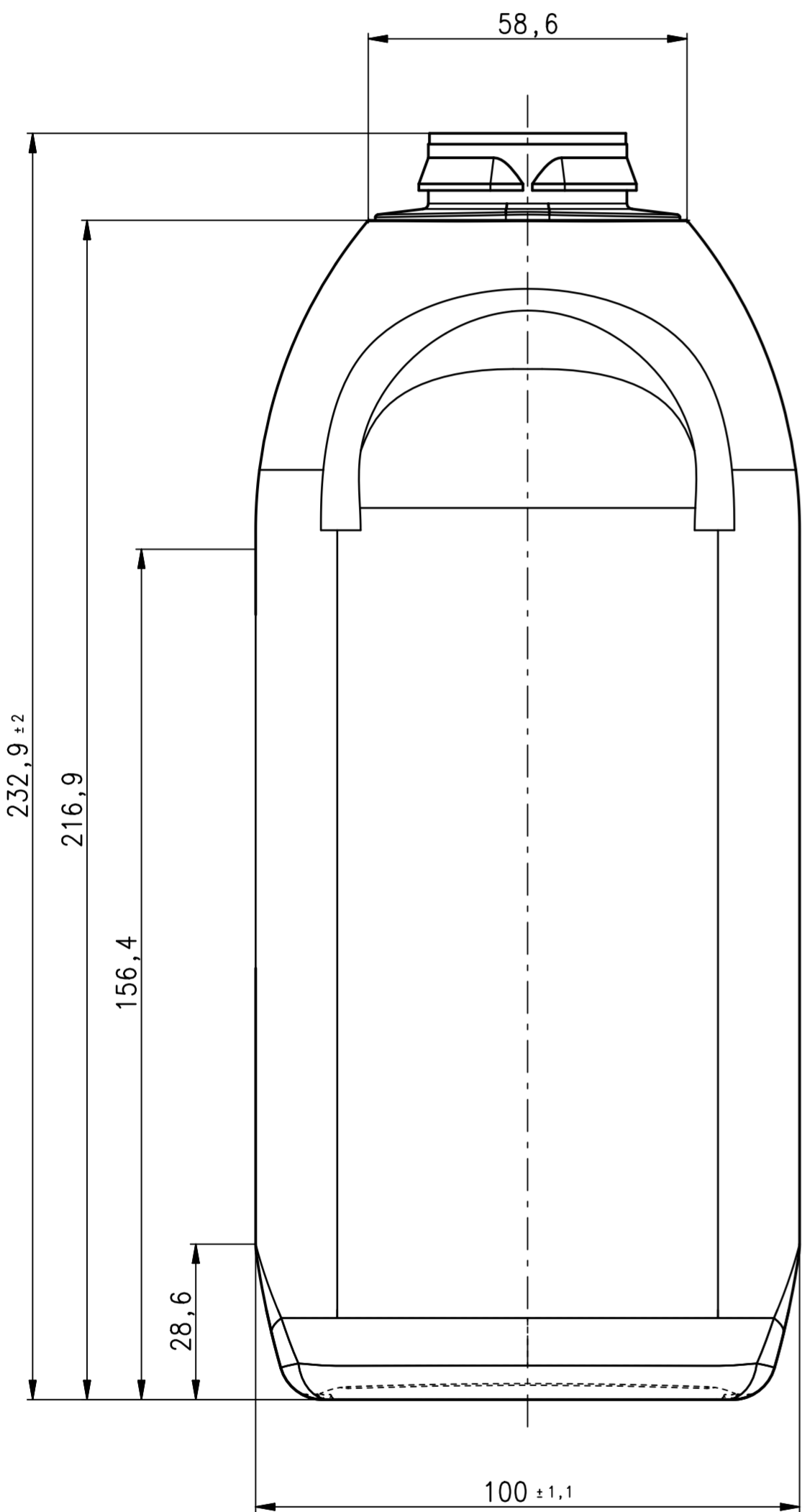
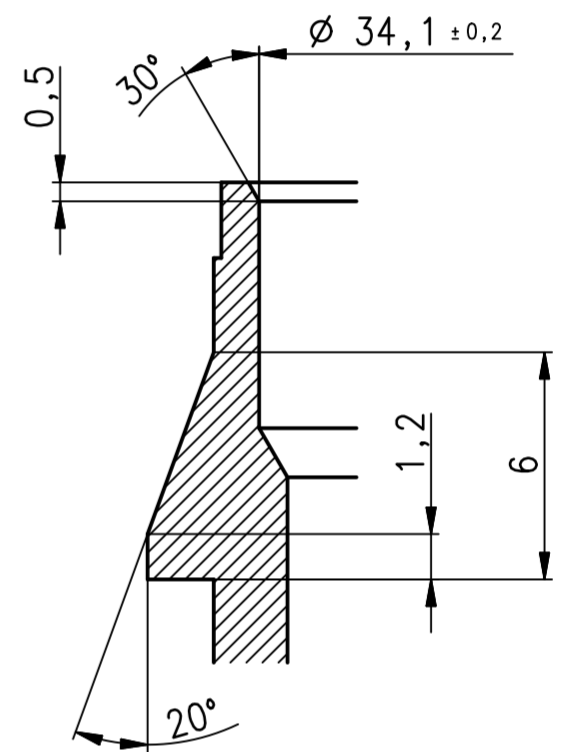

MATERIAL: HDPE
WEIGHT: $50 \pm 2g$
VOLUME: $1050 \pm 20ml$ BRIMFULL

Index		Modification:		Name	Date	Index		Modification:		Name	Date
Scale:		1:1		Name	Date	Scale:		1:1		Name	Date
Prepared:		Schuetz Stephanie		08.Jun.12		Reviewed:		HT		08.Jun.12	
ALPLA reserves all rights to the technical IP contained in the document		Supersedes:				Superseded by:					
Title:		Lustenauer Senf 1kg		Weight:		00kg		Art.No.:		Page: 1 of 1	
Drawing No.:		9202_012_028_01		Revision:		00					

ALPLA