

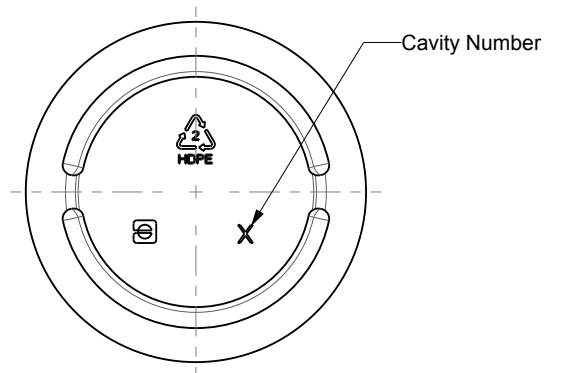

SECTION X2-X2
SCALE 3:1

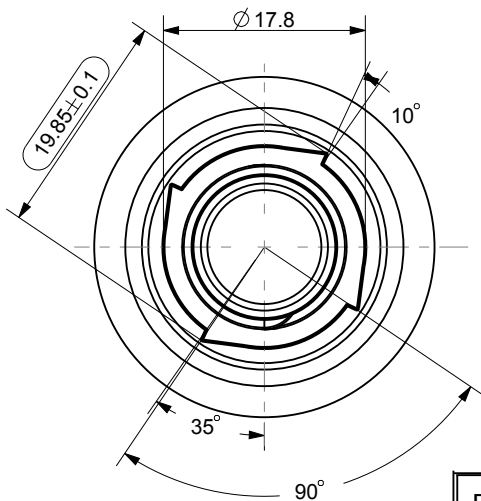

DRAWING No : BTL_0129_T		A4				
SCALE : 1.5 : 1 / 5 : 1		E	new mold	10/09/15		
	DATE	NAME	D	Change inside neck diameter and tolerance	31/05/13	N.G.
DRAWN	03/03/03	M.D.	C	Change inside neck diameter and tolerance	29/03/13	N.G.
CHECKED	10/09/15	S.T.	B	Change inside neck diameter and tolerance	15/02/12	N.G.
			A	Change inside neck diameter and tolerance	11/05/09	N.G.
 ARGO		INDEX	MODIFICATION	DATE	NAME	
				REV	SHEET	
We reserve all rights in this document and in the information contained there in		SUPERSEDES : 31/05/13			4	1
		REPLACED BY : S.T.				1