

predetermined breaking/cutting area

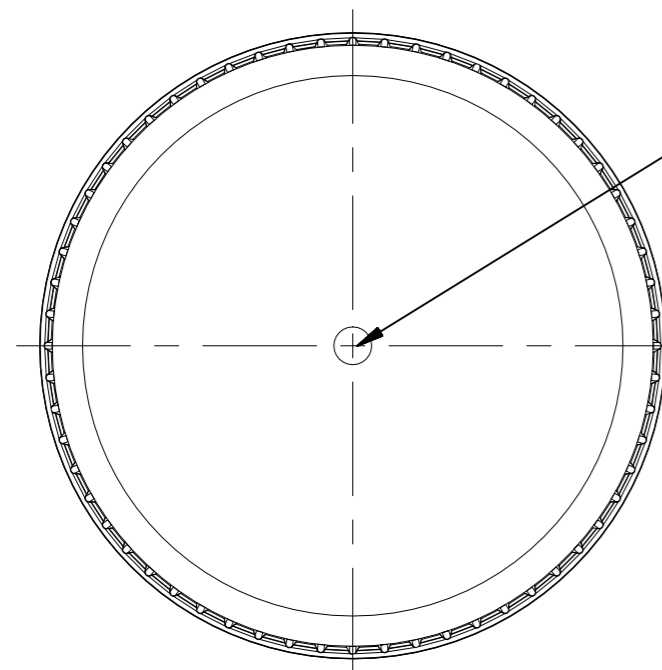

injection gate

SECTION
SCALE 3:1

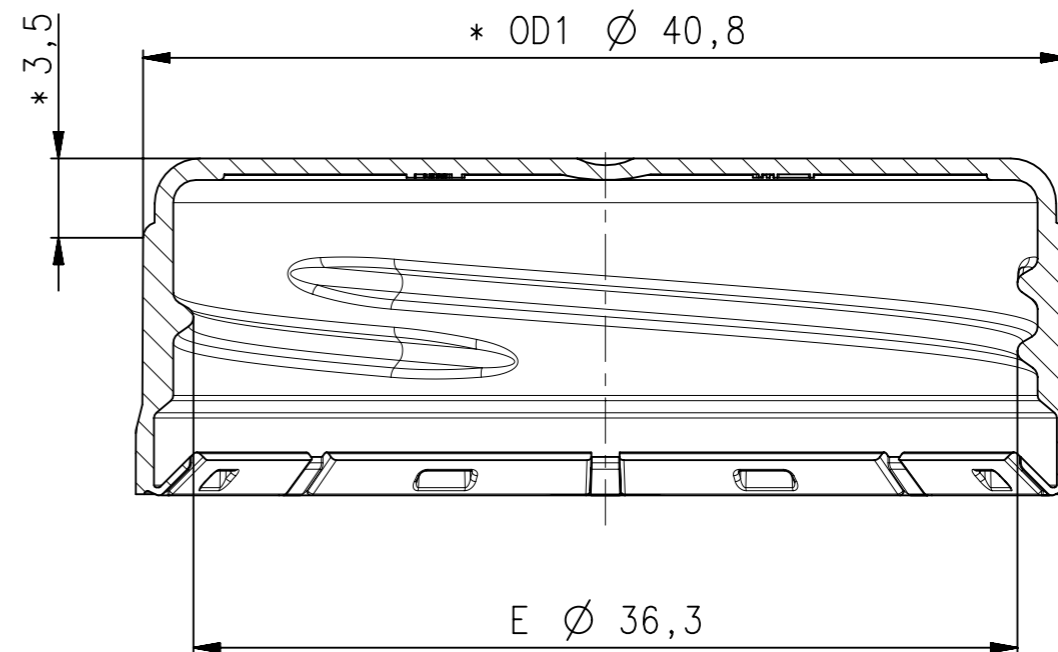

Info: system with liner

THREAD DETAIL:

PITCH: 9,0mm
 TURNS: 0,33
 3 START THREAD
 spacing between thread profile: 3,0 (9,0/3)

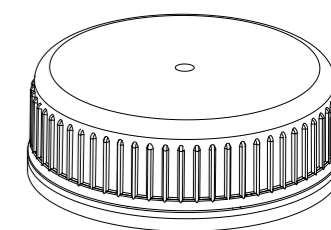

Attention!
 Data associated to this drawing is embedded directly from external sources.
 File reference: V255 38mm Milchverschluss Zeichnung.pdf

* measuring point

Index		Modification:		Name	Date	Index		Modification:		Name	Date
Scale:				Name		Date		ALPLA			
2:1				Prepared: Suess Georg		27. Jul. 21					
1:1/3:1				Reviewed:							
ALPLA reserves all rights to the technical IP contained in the document				Superseded:				Art.No.:			
				Superseded by:				Page: 1 of 1			
				Weight: 0.00kg				Drawing No.:			
Title:				ASC 38/3				Revision: 00			
								9301_021_123_01_C1			