

Mündung M2:1
PN 194.0
Windungen: 1,25 ohne Ein- und Auslauf
Steigung: 4mm

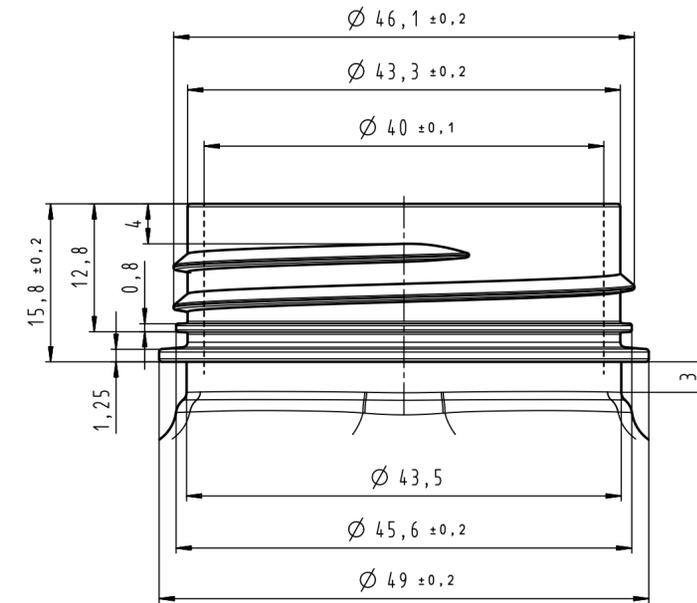

Gewindedetail M5:1

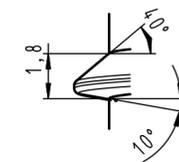

Material: PET
Gewicht : 40g±1g
Volumen : 1070ml ±15ml

CAD - Zeichnung		Allgemeine Toleranzen		Masstab 1:1	E5
12-212-465		Blasartikel DIN 7108 grob (ISO/TC 3, DIS coarse series) Spritzgussartikel DIN 7108 fein (ISO/TC 3, DIS fine series)		Wkz-Nr. : 8072 / 7035 (a) (b)	
		2012	Datum	Name	1000ml PET
		Bearb.	26.11.2012	Nobis	
		Gepr.	27.11.2012	Nobis	
		Ersatz für:			A2-12-16950b
		Ersetzt durch:			
b	Wkz-Nr. 7035 ergänzt	14.10.13	No.	 BLASFORMEN	
a	Wkz-Nr. ergänzt	04.12.12	No.		
Zust.	Änderung	Datum	Name	Blatt 1/1	